

AC3010 1.2 GHZ INTELLIGENT BROADBAND AMPLIFIER



The AC3010 is a single active output amplifier with 48 dB maximum gain. The amplifier stages are based on extreme high performance GaN solution that makes the usable gain range especially wide and allows high output level. Integrated interstage gain and slope controls optimise the flatness performance.

AC3010 has a USB connector for local configuration with a PC or mobile device. It has a slot for transponder module, which allows full remote monitoring and control of all node parameters. The transponder unit measures the forward and return path signal levels and enables the automatic forward and return path alignment function.

For upgrading return path to 85 MHz or 204 MHz there is no need to change the return amplifier, but only diplex filters and the return output module.

Features

- 1.2 GHz bandwidth
- Electrical adjustments
- Forward amplifiers use the newest GaN HEMT technology
- GaAs push-pull return amplifier on motherboard
- Temperature compensated forward and return path
- Excellent ESD and surge protection
- Remote power supply with PFC
- PC and Android user interface
- With a transponder plug-in module:
 - CATVvisor, HMS or DOCSIS remote connection
 - Remote ingress switch control
 - ALSC with fully user programmable pilots
 - Downstream spectrum analyser
 - Upstream signal monitoring with automatic plug-in and ingress control
 - True plug-and-play with single pushbutton alignment
 - Return path pilot generator

Technical specifications

Parameter	Specification	Note
Downstream signal path (values with diplex filters)		
Frequency range	85...1218 MHz	
Return loss	20 dB	1)
Maximum gain	48 dB	2)
Pivot frequency selection	1.0 / 1.2 GHz	3)
Nominal interstage slope, distribution mode	13 dB	3)
Nominal interstage slope, trunk mode	7 dB	4)
Input gain control	-20...0 dB	5)
Input slope control	0...20 dB	5)
Interstage gain control, ALC	-10...0 dB	6)
Interstage gain control, output	-10...0 dB	5)
Interstage slope control, distribution mode	9...19 dB	6)
Interstage slope control, trunk mode	3...13 dB	6)
Flatness	±0.5 dB	7)
Group delay	2 ns	8)
Test point	-20 dB	9)
Transponder connection	-19 dB	10)
Input by-pass attenuation	-2.5 dB	
Noise figure	8.5 dB	11)
$U_{\max(112 \times \text{QAM channels}) @ 1.0 \text{ GHz}}$	115.0 dB μ V	12)
$U_{\max(138 \times \text{QAM channels}) @ 1.2 \text{ GHz}}$	112.0 dB μ V	13)
CINR	See curves	14)
CTB 41 channels	118.0 dB μ V	15)
CSO 41 channels	119.0 dB μ V	15)
Upstream signal path (values with diplex filters)		
Frequency range	5...204 MHz	
Return loss	18 dB	16)
Maximum gain	28	17)
Ingress switching	0 / -6 / < -45 dB	
Gain control	0...28 dB	18)
Slope control	0...15 dB	19)
Flatness	±0.5 dB	
Transponder connection	-37 dB	20)
Noise figure	6.5 dB	21)
CINR	See curves	22)
General		
Power consumption (65 & 90 / 230 V _{AC})	28 / 30 W	23)
Supply voltage	27...65 / 40...90 / 205...255 VAC	24)
Maximum current feed through	7.0 A / port	25)
Hum modulation	70 dB	25)
Resistance for remote current	25 m Ω / port	
Input/Output connectors	PG11 thread, other types available	
Test point connectors	F female	
Dimensions	245 x 255 x 100 mm	h x w x d
Weight	3.0 kg	
Operating temperature	-40...+55 °C	
Class of enclosure	IP67	26)
Environmental (salt mist, cyclic)	IEC 60068-2-52, severity 1	
Safety	EN60728-11 / EN60065	
EMC	EN50083-2	
ESD	4 kV	27)
Surge	6 kV (EN 60728-3)	

Notes

- 1) The limiting curve is defined at 40 MHz -1.5 dB / octave.
- 2) This is gain in room temperature at highest frequency. Gain is defined with 2 diplex filters. All other used plug-in modules and settings have 0 dB value. Nominal gain is 44 dB.
- 3) Slope is defined between 85 MHz and 1218 MHz. Interstage fixed slope has a selectable pivot frequency.
- 4) Maximum gain at 1.2 GHz is 6 dB lower when trunk mode is in use.
- 5) Electrical control with 1 dB step.
- 6) Electrical control with 0.1 dB step, used by ALSC and temperature compensation.
- 7) Typical value. The guaranteed value is ± 0.8 dB. Flatness is with nominal settings and 2 diplex filters. All other used plug-in modules are 0 dB jumpers. The specification is valid 5 MHz after the starting frequency of the selected diplex filter.
- 8) Typical value for 4.43 MHz band, $f > 120$ MHz. CXF065 diplex filters are in use.
- 9) Output TP has a tolerance of ± 0.8 dB between 85...1006 MHz and ± 1.0 dB between 1006...1218 MHz. The TP is defined with 0 dB plug-in as OUTPUT MODULE 1. This connection can be used also as an injection point for a test signal of return channel. Input TP is a transformer type with ± 1.5 dB tolerance between 5...1006 MHz. At higher frequency tolerance is ± 2.0 dB. Input TP tolerance is defined with 3 dB input attenuator.
- 10) Level difference between transponder connection and output 1. Tolerance ± 0.5 dB.
- 11) Typical value with full gain and 13 dB slope. Guaranteed value is 1.0 dB worse.
- 12) Typical value according to IEC60728-3. Channels have 13 dB cable equivalent slope between 85...1006 MHz and signal level has been defined at 1002 MHz. BER measurement has been done on the worst channel between 110...1006 MHz.
- 13) Typical value according to IEC60728-3. Channels have 13 dB cable equivalent slope between 85...1218 MHz and signal level has been defined at 1210 MHz. BER measurement has been done on the worst channel between 110...1218 MHz.

14) CINR according to IEC60728-3. Full digital loading up to 1218 MHz.

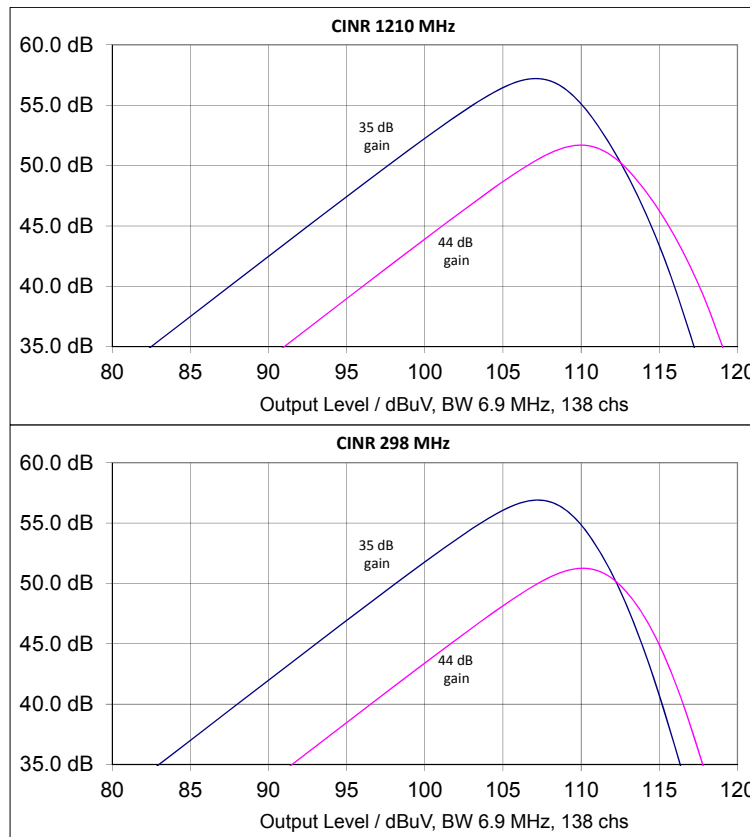

- 15) According to IEC60728-3. Tested with full gain and 13 dB slope between 85...1006 MHz. Signal level is defined at 862 MHz. All results are typical values in room temperature.
- 16) $8 < f < 80$ MHz, $f > 80$ MHz -1.5 dB / octave.
- 17) Upstream amplifier is built on the motherboard. 28 dB gain is available in 65 MHz (AC6254) and 85 MHz (AC6255) mode. In 204 MHz mode (AC6256) gain is 29 dB.
- 18) Electrical control with 1 dB step. This control is automatically divided between interstage and output attenuators.
- 19) Electrical control with 1 dB step. Pivot point of slope control can be changed by changing return path output module. Slope adjustment range depends on installed return path output module:
 AC6254 (65 MHz): 0...15 dB
 AC6255 (85 MHz): 0...15 dB
 AC6256 (204 MHz): 3...18 dB
 AC6257 (204 MHz): 0...18 dB (flatness spec not guaranteed in 15...18 dB range).
- 20) Level difference between return path input and transponder transmit pin when return path gain is 28/29 dB. This value increases linearly to -25 dB when return path gain decreases to 16/17 dB, after that it stays at -25 dB. Tolerance ± 1 dB.
- 21) Typical value.

22) CINR according to IEC60728-3.

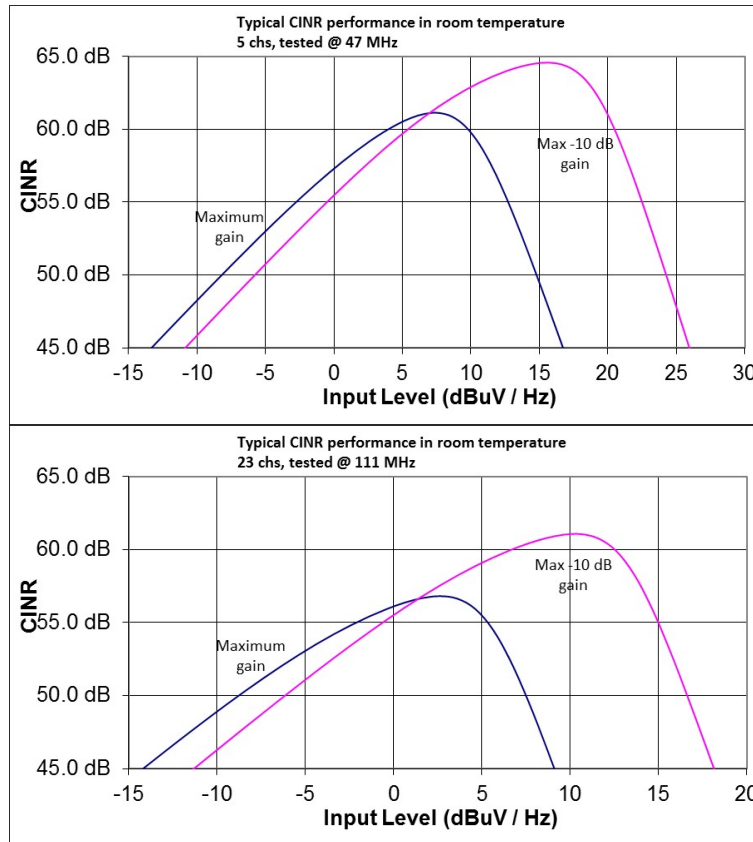

- 23) Without transponder unit.
- 24) 40...90 VAC power supply is purposed only for quasi-square wave form supply voltage.
- 25) At any frequency from 15 to 1006 MHz when the remote current is less than 7 A. Hum is 65 dB between 10...15 MHz and 1006...1218 MHz. Value is valid for one signal port. 15 A is the maximum total current which can be locally injected into all ports simultaneously.
- 26) The housing is tested to be class of IP67. However, in standard delivery condition the lowest side wall is equipped with a 1 mm ventilation hole. Then the practical enclosure class is IP54.
- 27) EN61000-4-2, contact discharge to enclosure and RF-ports.

Management functions

- Status LED for alarm indication
- Return path ingress switch on / attenuated / off control
- Remote and local voltage measurements with alarms
- Internal temperature measurement with alarms
- Full electrical control of all forward and return path alignments
- Easy and fast intelligent gain control with manual override
- Automatic diplex filter type detection
- Indication of universal plug-in module presence
- Electrical control of forward path plug-in usage
- Individual electrical control of return path plug-in usage
- Electrical control of forward path frequency range
- Return path automatic alignment
- Configuration change monitoring with alarm
- Service terminal monitoring with alarm
- Uptime, total uptime and reset counters for power outage statistics
- User notes can be stored into amplifier memory
- Fully user configurable alarm limits and severities
- Alarm log stored into non-volatile memory for easy troubleshooting
- Amplifier configuration and accessory information stored in amplifier memory
- Fast local software update via USB also without power supply

Transponder units

Functionality	AC6915 RIS receiver	AC6918 ALSC unit	AC6980/1/3 transponder	AC6991/2 transponder
Leds for remote connection and ALSC status	X	X	X	X
RIS receiver for remote ingress switch control	X	X	-	-
Full remote monitoring and control, CATVisor / HMS	-	-	-	X
Full remote monitoring and control, DOCSIS	-	-	X	-
ALSC for gain and slope control with user configurable pilot and reserve pilot frequencies, types and levels	-	X	X	X
User configurable versatile automatic alignment	-	X	X	X
Full automatic alignment with single pushbutton	-	-	X	X
Lid status monitoring with alarm	-	-	X	X
Modem rx and tx signal level monitoring with alarms	-	-	-	X
Spectrum analyser for forward path level measurement with alarms	-	-	X	X
Ingress analyser for return path level measurement with alarms	-	-	X	X
Automatic ingress switch and return path plug control based on ingress with alarms and configurable delays	-	-	X	X
Return path pilot generator with 4 user programmable pilot frequencies and levels	-	-	-	X

Compatibility

All accessories used with this product should be the newest generation available. Proper operation can guaranteed only with up-to-date accessories.

Block diagram

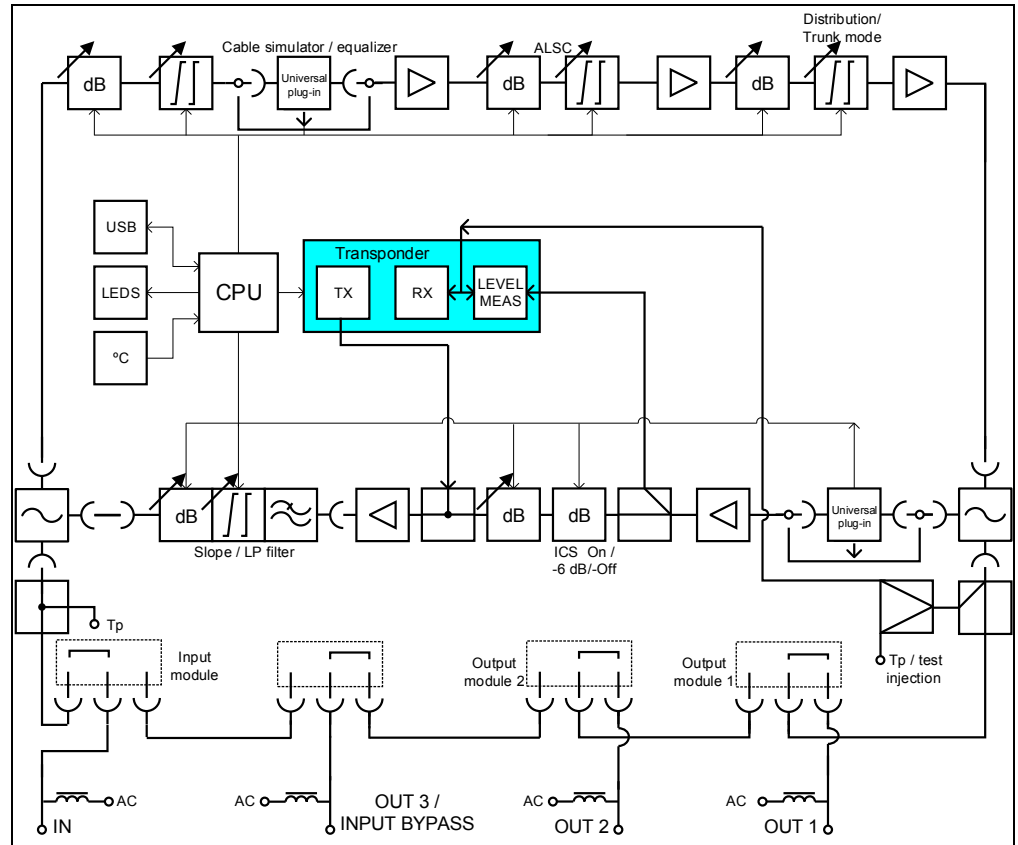

Ordering information

AC3010 configuration map

	1	2	3	4	5	6	7	8
	1 2	1 2 3 4	1 2	1 2 3	1	1	1 2 3	1
AC3010		-		-		-		-

1-1 Gain and housing

B 44 dB, 1.2 GHz, 1st gen.

D 44 dB, 1.2 GHz, 3rd gen.

L 44 dB, 1.2 GHz, ventilation hole closed

1-2 Power supply

A Local powering, euro plug (230 VAC)

B Remote powering with cable clamp (65 VAC)

C Local powering, UK plug (230 VAC)

D Remote powering with cable clamp (90 VAC)

4-1 Forward path universal plug

X None

4-2 Output modules

A 0 dB (AC6120)

B Splitter -3.7 dB, (AC6124 + AC6120)

X None

4-3 Future reservation

X None

2-1 Input connection (first from left)

A PG11

B 5/8"

C IEC

D 3.5/12

E F

K Customers specific option

2-2 Input by-pass/output 3 connection

A PG11

B 5/8"

C IEC

D 3.5/12

E F

K Customers specific option

X None (PG11sealing plug)

2-3 Output 2 connection

A PG11

B 5/8"

C IEC

D 3.5/12

E F

K Customers specific option

X None (PG11sealing plug)

2-4 Output 1 connection (first from right)

A PG11

B 5/8"

C IEC

D 3.5/12

E F

K Customers specific option

5-1 Return path universal plug

A Ingress blocker (AC6223)

X None

6-1 Transponder module

D ALSC+RIS module (AC6918)

E Transponder and ALSC module (AC6992)

F RIS module (AC6915)

G DOCSIS transponder (AC6981)

H DOCSIS transponder (AC6983)

X None

7-1 Communication protocol / application software

X None

A CATV/visor compatible

B HMS/SNMP compatible

C Customers specific

7-2 Settings

X Factory default

A Customer specified (ECML file)

7-3 Product keys (software features)

X None

C Auto alignment, spectrum and ingress analyser, pilot generator

3-1 Input module

A 0 dB, no by-pass (AC6110)

X None

3-2 Diplexer filters

A 65/85 MHz (2 x CXF065 + AC6254)

B 85/105 MHz (2 x CXF085 + AC6255)

D 204/258 MHz (2 x CXF204 + AC6257)

G 65/85 MHz (CXF065+CXF065 19 + AC6254)

H 85/105 MHz (CXF085+CXF085 19 + AC6255)

K 204/258 MHz (CXF204+CXF204 19 + AC6257)

L Customers specific option

X None

8-1 Customer specific selections

B Customers specific option

D Mounting bracket AC6427

X None

DOC0023024
Rev 026

Gain and housing selections (1-1) A&B (1st gen.) support electrical output3/by-pass selection.
 Mother board D (3rd gen.) has a plug-in module for output3/by-pass selection.
 Specification sheets lower than v50 are defining the 1st gen. device.