

VB243

ASI INTELLIGENT REDUNDANCY SWITCH

The VB243 provides full dual path redundancy for ASI signals with autonomous operation and deep signal analysis on both signal paths for the ultimate switching decision making. Front panel controls with illuminated buttons offer local override control and a clear visual indication of the active switching path. The redundancy switch offers three distinct modes of operation making it suitable for any real-life operational challenges. These are Automatic mode, Manual mode and SuperLocal mode.



Technologies

Bridge Technologies options are designed to enhance the overall ability and performance of accurate monitoring in the broadcast environment

Click below to learn more about compatible technology options:

[Eii™](#) [ETR290™](#)

Environmental

[Euroenvironment](#) [RoHS](#) [WEEE](#)

Chassis Options

[ACC](#) [DCC](#) [EC](#) [EC-DC](#)

Overview

The VB243 INTELLIGENT REDUNDANCY SWITCH has multiple layers of redundancy. The 1RU chassis offers dual redundant power supplies and the VB243 switching card has magnetically latching relays to protect against signal disruption even during a complete loss of power.

The VB243 switch module actively taps off a small portion of the input signal from both inputs, amplifies it and then feeds it to the neighbouring VB242 ASI input module via two factory fitted cables. This allows monitoring and analysis to take place on both inputs simultaneously for switching purposes. If any problem in any parameter is detected preset rules apply and the unit will check the opposite input for the same failure and perform a switch if no failure is detected.

To avoid switch flapping a minimum switchback time can optionally be configured. All the parameters in the implementation of the TS 101 290 specification can be utilised as switching criteria.

In automatic mode the VB243 system is fully independent and makes its own switching decisions based on the preset switching rules. In manual mode the unit can be controlled from any overlying NMS system via the extensive XML-based Eii (External Integration Interface) or via SNMP triggers.

The VB243 also features a unique superLocal mode feature to deliberately cut off overlying NMS control for emergency manual override situations via the front button panel. All parameters can be controlled via the built-in web GUI. The web GUI also gives a visual overview of parameters used in switch decisions and system status.

The VB120 blade offers a bonus HD-BNC ASI input port with TS 101 290 analysis support that can be used for ad-hoc monitoring in addition to the two main ASI input ports used on the VB242 blade should the need arise.

VB243 SWITCHING MODULE BLOCK DIAGRAM

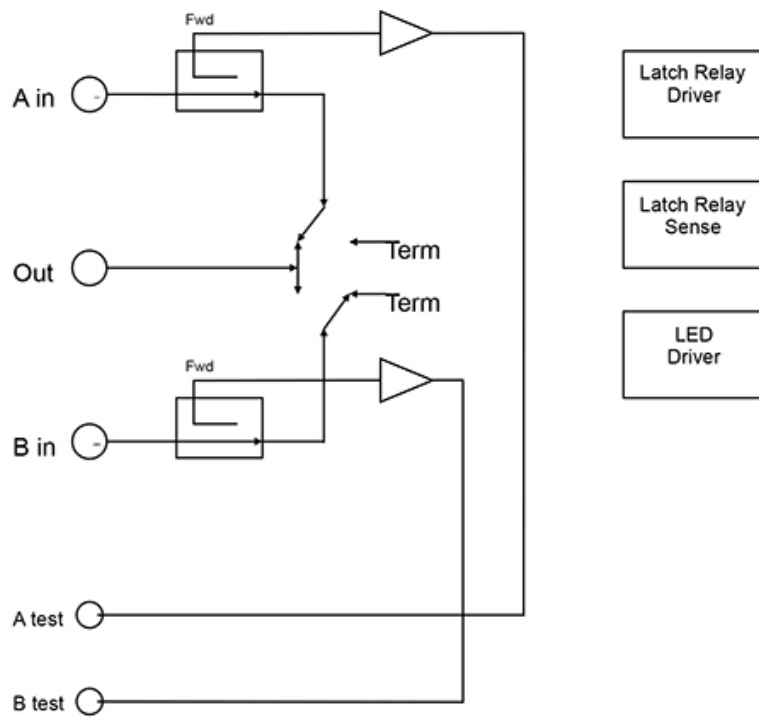

Tech Features

VB243 ASI INTELLIGENT REDUNDANCY SWITCH

- 2:1 switching operation with latching relays
- Simultaneous monitoring of two ASI switching inputs plus ad-hoc ASI input
- 2 DVB-ASI inputs EN 50083-9, Annex B – BNC connector
- 1 DVB-ASI output EN 50083-9, Annex B – BNC connector
- Supports burst mode, spread mode, M2S
- Supports 188 or 204-byte packet length
- 75 ohm BNC (female) connectors
- Spare ASI input: 75 ohm HD-BNC (female)
- Switching modes: automatic, manual, superLocal
- TS 101 290 priority 1, 2 and 3 switching criteria
- PID analysis, Service analysis, bandwidth overview, table analysis
- Automatic or manual TS recording of up to 200MB
- Thumbnail extraction
- Configurable alarm severity level
- PSIP support (ATSCA/78)
- Exportable logs
- Management port: 10/100/1000-T RJ45
- Alternative SFP port
- Web-based element management
- 9-pin DSUB alarm relay
- USB type-A port for maintenance

PHYSICAL AND ENVIRONMENTAL CHARACTERISTICS

- Input voltage: 100-240V AC, 50/60 Hz, Dual power supply, optional -48V DC
- Power consumption: 25W max
- Dimensions: 1RU
- Operating temperature: 0 to +45 deg.C
- Storage temperature: -20 to +70 deg.C
- Relative humidity: 5% to 95% (non condensing)
- Compliance: CSA, UL, CE

MECHANICAL SPECIFICATIONS

- Standard 19 1RU rack-mount
- W x H x D: 483 x 43 x 400 mm
- Weight: 8,2 kg fully populated

Software Options

Information is not available online for this product. Please contact your representative.

Ordering Codes

VB243-ASI-SWITCH – ASI Intelligent Redundancy Switch. EC/VB120/VB242/VB243/SWITCH-OPT

Documentation

[User Manual – Download](#)

[Quick Start Guide – Download](#)

Related Products



VB120

IP MONITOR PROBE



VB242

ASI SWITCHED DUAL INPUT